

hire      somewhere      word root con means together  
 nourish      repeated      ripen  
 contract      paper      composition  
                          firm      given      commemorate  
 arrow  
 wounded  
 contacts  
 scarf      **Word Study**      commotion  
                          **Week of \_\_\_\_\_**  
                          higher      instant  
 impertinently      clothing      perimeter  
                          sought      added      canoeing  
                          word root com means with or together      astonish      weaken  
 echoed      oven      dominoes  
                          churlishly

**My Name:** \_\_\_\_\_

**Your Words**

Pick 3 to do:

- page 1
- page 2
- pages 3-4
- page 5

**Math Break**

Pick 1 to do:

- page 8
- page 9
- page 10
- page 11

**Spelling Workout**

Pick 9 to do:

- page 12
- page 13
- page 14
- page 15
- page 16
- page 17
- page 18
- page 19
- page 20
- page 21
- page 22

**Spelling Break**

Pick 1 to do:

- page 23
- page 24
- page 25

**Challenge Words**

Do this:

- page 26

**Vocabulary**

Do all of these:

- page 6
- page 7

Name: \_\_\_\_\_



perimeter • canoeing • higher • impertinently • echoed • repeated  
contract • arrow • hoeing • wounded • weaken • commotion • oven  
hire • ripen • rudely • somewhere • astonish • churlishly • paper  
contacts • instant • added • dominoes • commemorate • clothing • scarf  
composition • given • sought • nourish • firm

Write four words that you are unable to define.

_____	_____
_____	_____

Write ten of the most difficult words to spell.

_____	_____
_____	_____
_____	_____
_____	_____
_____	_____

Write ten words that you have not yet written.

_____	_____
_____	_____
_____	_____
_____	_____
_____	_____

Name: \_\_\_\_\_

## Finding Words Multiple Times

Look for words to the RIGHT, to the LEFT, UP, or DOWN.

I N P E C O M M E M O R A T E  
 M E I N S O U G H T N E V I G  
 P P E E O F N C E D E O H C E  
 E I T T S C A R F H I G H E R  
 R R A A N O I T I S O P M O C  
 T S R R C T D N E P I R G R S  
 I E O O O C O S C A R F I E O  
 N O M M N A M F R A C S V H U  
 E N E E T R I N E P I R E G G  
 N I M M R T N F R A C S N I H  
 T M M M A N O H O E I N G H T  
 L O O O C O E V C H I G H E R  
 Y D C C T C S T C A R T N O C

Answers for blanks:

I found CONTRACT \_\_\_\_ time(s).

I found HIGHER \_\_\_\_ time(s).

I found SOUGHT \_\_\_\_ time(s).

I found COMPOSITION \_\_\_\_ time(s).

I found COMMEMORATE \_\_\_\_ time(s).

I found DOMINOES \_\_\_\_ time(s).

I found ECHOED \_\_\_\_ time(s).

I found GIVEN \_\_\_\_ time(s).

I found HOEING \_\_\_\_ time(s).

I found SCARF \_\_\_\_ time(s).

Name: \_\_\_\_\_

Picture Dictionary

Draw a picture of 11 of your words. Write the word in cursive.



EXAMPLE. laughed

1. \_\_\_\_\_

2. \_\_\_\_\_

3. \_\_\_\_\_

4. \_\_\_\_\_

5. \_\_\_\_\_

Name: \_\_\_\_\_

6. \_\_\_\_\_

7. \_\_\_\_\_

8. \_\_\_\_\_

9. \_\_\_\_\_

10. \_\_\_\_\_

11. \_\_\_\_\_

Name: \_\_\_\_\_

U M R G B A L A R M R R F A P  
 D I A R F A B S E N T H L F E  
 A G A A C H I E V E O A E N  
 T M E T A M I X O R P P A L W  
 E Y L U F W A A F U U N V C R  
 A R T I F I C I A L I V E P L  
 M G N A E S T N U O C C A A A  
 O N D P R U A C L L T A E W O  
 A A T C A Y H S I L O B A A A  
 B I O Y A N Y T H I N G R K R  
 A R R O W L E I C X B P C E T  
 M M A S L E E P A P H E I H A  
 R A V L M L K N N G M V P H N

"A" Words

A \_\_\_\_\_ A \_\_\_\_\_  
 A \_\_\_\_\_ A \_\_\_\_\_  
 A \_\_\_\_\_ A \_\_\_\_\_  
 A \_\_\_\_\_ A \_\_\_\_\_  
 A \_\_\_\_\_ A \_\_\_\_\_  
 A \_\_\_\_\_ A \_\_\_\_\_  
 A \_\_\_\_\_  
 A \_\_\_\_\_

I found \_\_\_\_\_ "A" words.

What are 10 tens equal to?

\_\_\_\_\_

Write an even number with a seven in the tens place.

\_\_\_\_\_

$$\begin{array}{r} 75 \\ - 66 \\ \hline \end{array}$$

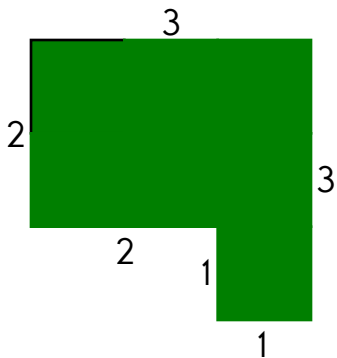

The perimeter is \_\_\_\_\_.

Locate where to put the number 448,000 and label the point K.

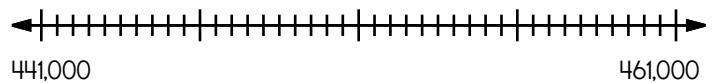

$$\begin{array}{r} 6 \\ 9 \\ + 9 \\ \hline \end{array} \qquad \begin{array}{r} 1 \\ 4 \\ + 5 \\ \hline \end{array}$$

Name: \_\_\_\_\_

### Word Roots to Know:

#### com

means with or together

composition

commotion

commemorate

#### con

means together

contacts

contract

Vocabulary is confusing. Get to the root of the problem with word roots! Here are the answers:

composition • contacts • together • contract • commemorate • commotion  
con

**This root** o k c o c e n u c n w g i c o n d o  
**means together** s c k u n o i o c x c c o n y j l n

**Word with** m t i g t u r c o m p o s i t i o n  
**the root: com** i s c o m p o s i t i o n s c m o m

**Word with** n o l c r o t c c o m m o t i o n u  
**the root: com** t o o l c o m m o t i o n m n z i p

**Word with** m h o p t c o m m e m o r a t e m m  
**the root: com** o t e m m t c o m m e m o r a t e m

**The root: con** t o g e t h e r t o g h e t h e r t  
**means** t o g a t h e r o c t o g e t h e r

**Word with** r c o n t r a c t x c c o t r a c t  
**the root: con** a c a n t r a c t c o n t r a c t d

**Word with** g c q c o n t a c t s k n t a k t s  
**the root: con** k o n t a k t s o m c o n t a c t s

Name: \_\_\_\_\_

SIMULTANEOUS FORESTALL PREVALENT

SYMMETRY FORMIDABLE

PREDICTION REBUFF INHABIT

INCHES VEHICLE MAJOR IMPAIR

SIESTA AGREE PERSONNEL MANUAL

CONDEMN UNDERLIE CHRONICLE

Circle the words that you know. I circled \_\_\_\_\_ words.

Use two of the words you know in a sentence.

---



---

Write five words that you don't know or want to know better.

---

Circle words to the RIGHT or DOWN. Every letter is used exactly ONCE.

B I T F I S F B Y I M P A I R  
P P O O N O O E N D A G R E E  
E R L R S W R U N D E R L I E  
R E D M Y I E S A C H E V C  
S V R I M N S I U S G M E M O  
O A E D M H T E W S I A H A N  
N L B A E A A S I T V J I N D  
N E U B T B L T N E E O C U E  
E N F L R I L A G W N R L A M  
L T F E Y T I N C H E S E L N



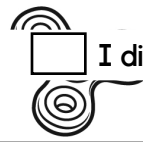

Name: \_\_\_\_\_

Get a fidget spinner! Spin it.

I needed to spin \_\_\_\_\_ time(s) to finish.

**Not Exact****Estimate - With a Good Guess**

$62 \div 9 \approx \underline{7}$

$58 \div 8 \approx \underline{7}$

$91 \div 10 \approx \underline{\quad}$

$94 \div 11 \approx \underline{\quad}$

$42 \div 12 \approx \underline{\quad}$

$70 \div 12 \approx \underline{\quad}$

$24 \div 5 \approx \underline{\quad}$

$13 \div 3 \approx \underline{\quad}$

$38 \div 4 \approx \underline{\quad}$

$31 \div 6 \approx \underline{\quad}$

$26 \div 7 \approx \underline{\quad}$

$72 \div 10 \approx \underline{\quad}$

$61 \div 9 \approx \underline{\quad}$

$53 \div 6 \approx \underline{\quad}$

$51 \div 7 \approx \underline{\quad}$

$18 \div 5 \approx \underline{\quad}$

$33 \div 4 \approx \underline{\quad}$

$20 \div 3 \approx \underline{\quad}$

$42 \div 8 \approx \underline{\quad}$

$47 \div 5 \approx \underline{\quad}$

$51 \div 12 \approx \underline{\quad}$

$28 \div 3 \approx \underline{\quad}$

$89 \div 11 \approx \underline{\quad}$

$32 \div 6 \approx \underline{\quad}$

$51 \div 7 \approx \underline{\quad}$

$14 \div 3 \approx \underline{\quad}$

$35 \div 10 \approx \underline{\quad}$

$33 \div 5 \approx \underline{\quad}$

$76 \div 11 \approx \underline{\quad}$

$92 \div 10 \approx \underline{\quad}$

$67 \div 8 \approx \underline{\quad}$

$29 \div 4 \approx \underline{\quad}$

$18 \div 4 \approx \underline{\quad}$

$43 \div 8 \approx \underline{\quad}$

$40 \div 12 \approx \underline{\quad}$

$22 \div 6 \approx \underline{\quad}$

$60 \div 7 \approx \underline{\quad}$

$87 \div 9 \approx \underline{\quad}$

$48 \div 7 \approx \underline{\quad}$

$83 \div 11 \approx \underline{\quad}$

$43 \div 8 \approx \underline{\quad}$

$51 \div 12 \approx \underline{\quad}$

Name: \_\_\_\_\_

$\frac{1}{2}$					$\frac{1}{2}$				
$\frac{1}{3}$			$\frac{1}{3}$			$\frac{1}{3}$			
$\frac{1}{6}$	$\frac{1}{6}$	$\frac{1}{6}$	$\frac{1}{6}$	$\frac{1}{6}$	$\frac{1}{6}$	$\frac{1}{6}$	$\frac{1}{6}$		
$\frac{1}{7}$	$\frac{1}{7}$	$\frac{1}{7}$	$\frac{1}{7}$	$\frac{1}{7}$	$\frac{1}{7}$	$\frac{1}{7}$	$\frac{1}{7}$		
$\frac{1}{8}$	$\frac{1}{8}$	$\frac{1}{8}$	$\frac{1}{8}$	$\frac{1}{8}$	$\frac{1}{8}$	$\frac{1}{8}$	$\frac{1}{8}$		
$\frac{1}{9}$	$\frac{1}{9}$	$\frac{1}{9}$	$\frac{1}{9}$	$\frac{1}{9}$	$\frac{1}{9}$	$\frac{1}{9}$	$\frac{1}{9}$		
$\frac{1}{10}$	$\frac{1}{10}$	$\frac{1}{10}$	$\frac{1}{10}$	$\frac{1}{10}$	$\frac{1}{10}$	$\frac{1}{10}$	$\frac{1}{10}$		

Compare.

$\frac{2}{9}$ ○ $\frac{2}{7}$	$\frac{3}{6}$ ○ $\frac{1}{2}$	$\frac{2}{3}$ ○ $\frac{8}{10}$	$\frac{2}{6}$ ○ $\frac{1}{3}$
$\frac{2}{8}$ ○ $\frac{7}{10}$	$\frac{1}{2}$ ○ $\frac{4}{6}$	$\frac{6}{9}$ ○ $\frac{2}{3}$	$\frac{2}{9}$ ○ $\frac{2}{3}$
$\frac{6}{7}$ ○ $\frac{6}{8}$	$\frac{1}{3}$ ○ $\frac{1}{2}$	$\frac{5}{9}$ ○ $\frac{1}{3}$	$\frac{4}{7}$ ○ $\frac{5}{10}$
$\frac{4}{6}$ ○ $\frac{2}{3}$	$\frac{4}{6}$ ○ $\frac{6}{8}$	$\frac{2}{10}$ ○ $\frac{6}{8}$	$\frac{7}{9}$ ○ $\frac{1}{2}$
$\frac{1}{2}$ ○ $\frac{4}{8}$	$\frac{1}{7}$ ○ $\frac{1}{6}$	$\frac{4}{9}$ ○ $\frac{4}{8}$	$\frac{3}{6}$ ○ $\frac{4}{8}$
$\frac{1}{2}$ ○ $\frac{2}{7}$	$\frac{1}{2}$ ○ $\frac{3}{10}$	$\frac{5}{10}$ ○ $\frac{1}{2}$	$\frac{1}{3}$ ○ $\frac{6}{7}$

Name: \_\_\_\_\_

The block above is the sum of the two blocks below. Fill in the missing blocks.

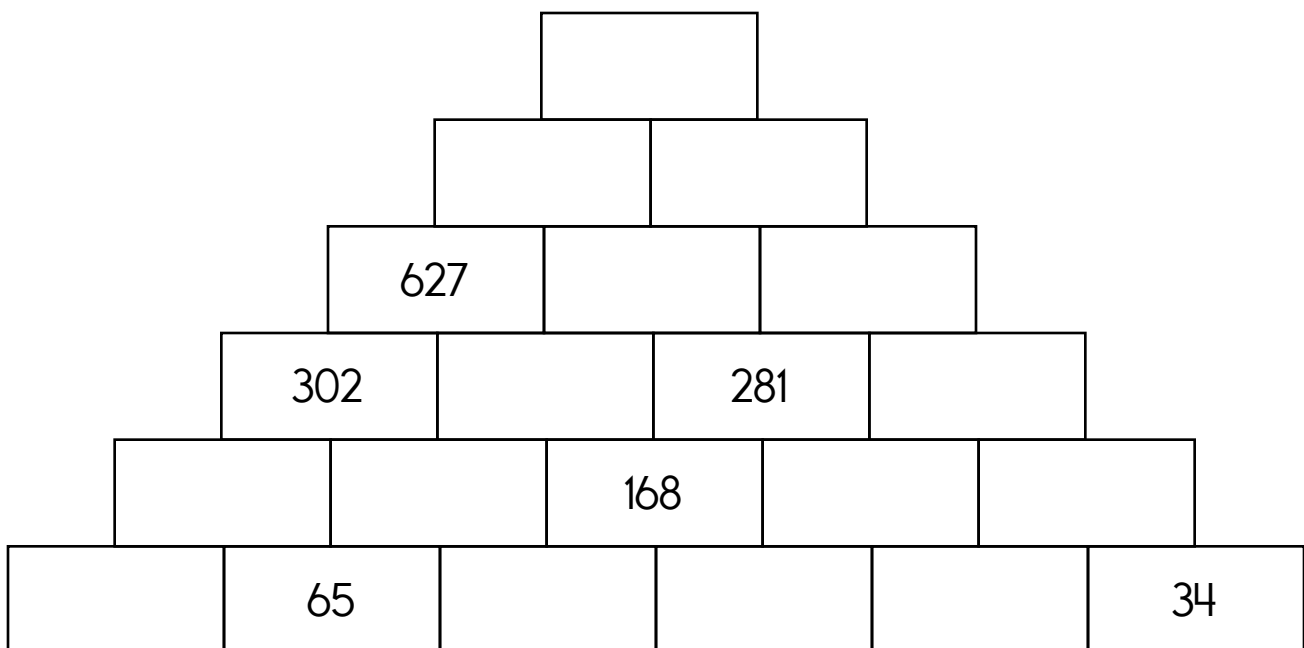
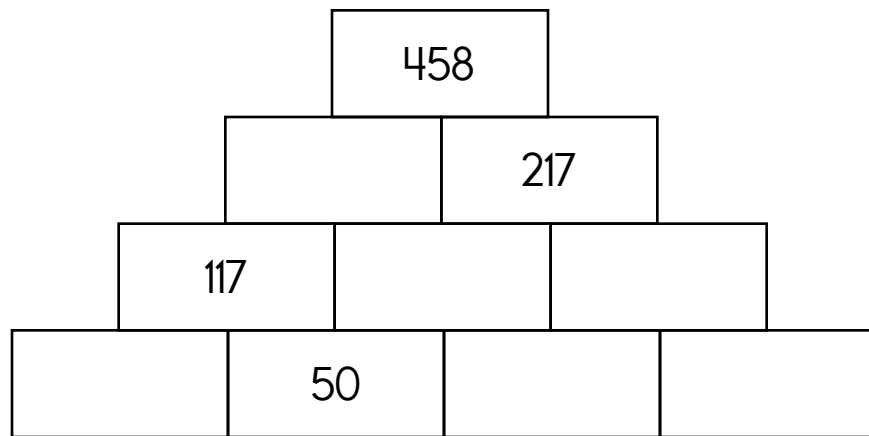
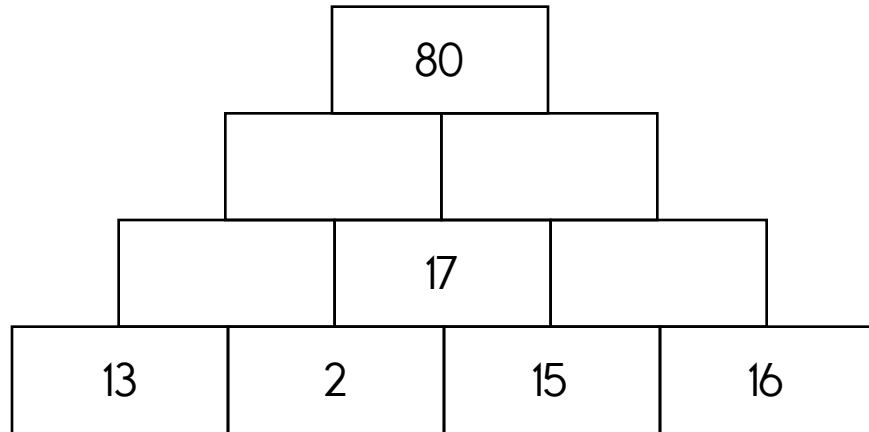

Name: \_\_\_\_\_

Mental break. Time to use a pencil for this more challenging page. Good luck!

This puzzle has a large number in the middle, which is the sum of the four numbers that surround it.

Example:

$$13 + 14 + 7 - 5 = 29$$

Example:

$$15 + 19 + 9 - 5 = 38$$

Sample:

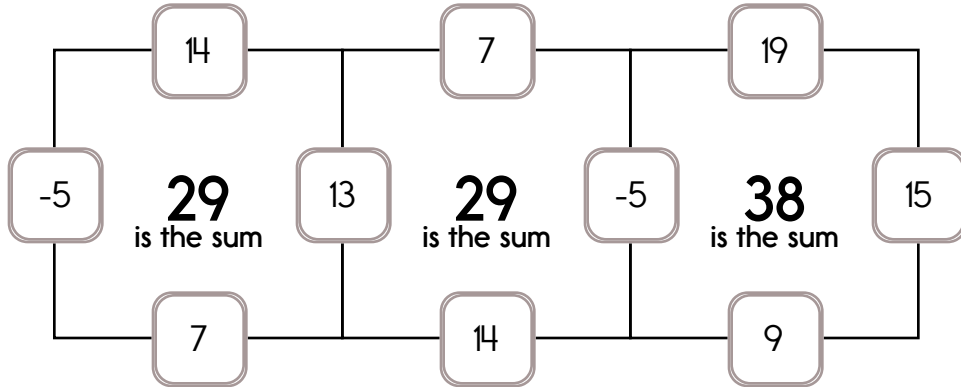

Fill in the missing numbers. How? The sum of the four surrounding numbers is in the center of each square. Exactly one of the four numbers has to be one of these numbers: -5, -3, or -7. The other three numbers have to all be DIFFERENT and must be from these: 14, 15, 19, 9, 7, or 13.

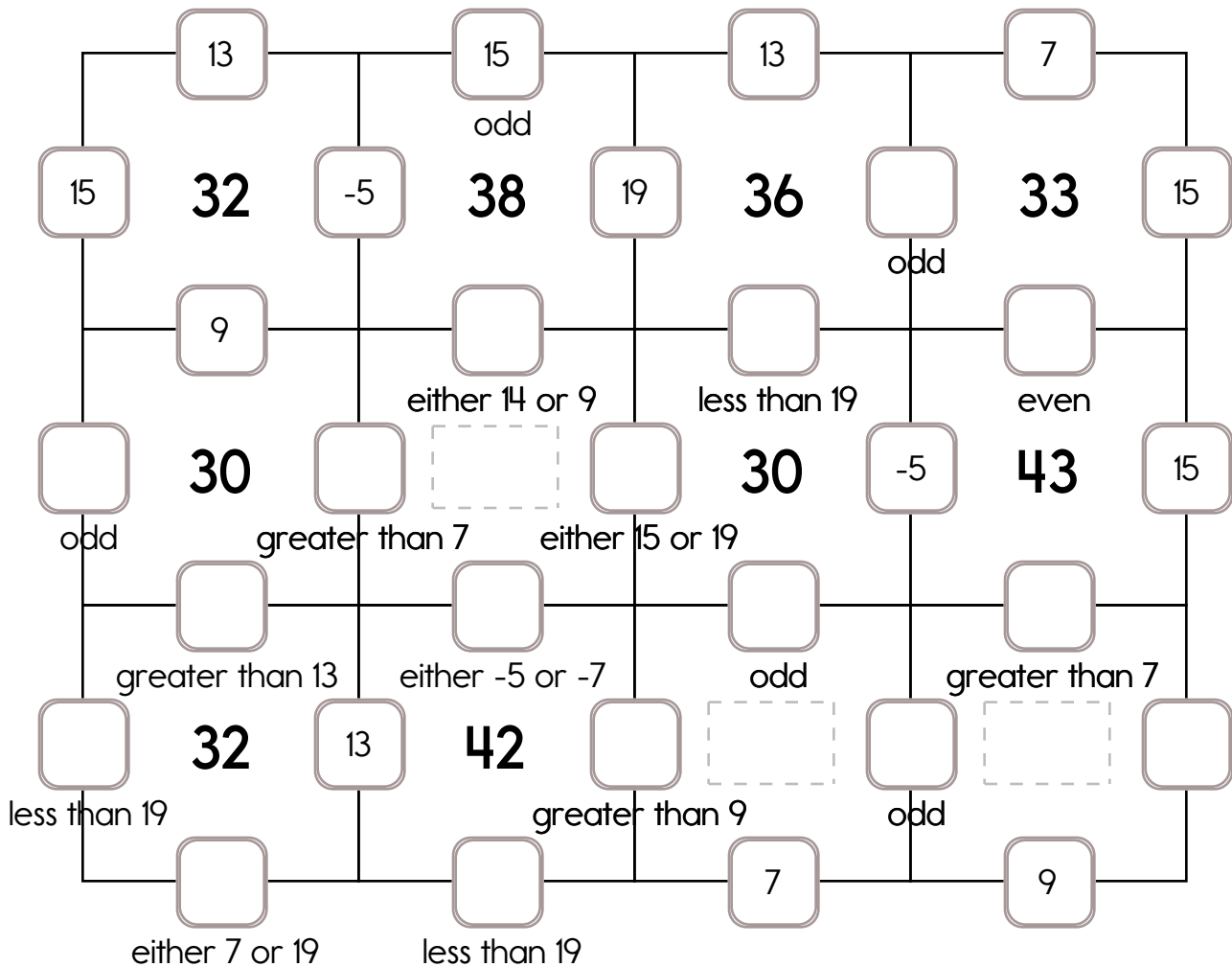

Name: \_\_\_\_\_

repeated e a b v s l r e p e a t e d e p r a q

commotion m g c o m o t i o n c o m m o t i o n

contract r a r c c o n t r a c t y c n o t n t

oven o v e n v w e o v i n n l g z a i m e

composition i y i x m o t o c o m p o s i t i o n

perimeter m v p e r i m e t e r u r e r r e t a

churlishly u c h u r l i s h l y i c v s k i r x

dominoes o d o m i n o e d d o m i n o e s o o

added d d d s p a d d e d e d e o d d e d t

impertinently n i m p e r t i n e n t l y j t n i f

nourish g y p s q o o n o u r i s h r n m u s

clothing t c o l t h i n g x g c l o t h i n g

hoeing o g i h o e i n g o w i h o p e i n g

echoed x g e c h o e d a h k i h d e h c e s

astonish i s t i n i s h z t a s t o n i s h i

scarf r r s c r a f q c a y p x a s c a r f

paper u a a r h a p e p e r p p p a p e r p

contacts k o n t a k t n c o n t a c t s c s c

firm f x m d f i r m f i m w j g m y k i r

hire u e d f s h h i w h i r e r h r e h r

sought o s t s u w t r q o u g s o u g h t t

higher h h x h i g e r h i g h e r e t e f i

canoeing w a m i e c a n o e i n g c g y a n l

arrow d a r r o w w r o o w w a r o o h o j

Name: \_\_\_\_\_

The vowels are missing in the word search.  
Fill in the missing vowels and circle the words.

N F  C T C S S Y L  
 H  N  S  C  C R  
 R  M D N  H    
 R M  M **S** T R  N N  
  R  **O**  F G T S  
 P R  T **U** C  H R T  
 R S  **G** T V     
 P  H  **H** S  R C N  
 W  N **T** N N N T T  
 R  S T  N  S H

CONTRACT • SOUGHT • HIGHER  
 NOURISH • HIRE • FIRM  
 COMMOTION • PAPER • INSTANT  
 CONTACTS • OVEN • ARROW  
 SCARF • ASTONISH

D C C N N O U R I S H F I R M  
 F R A C S O W E R I H C E M T  
 C N A C H U R L I S H L Y M I  
 O H R N C I N T H G U O S H R  
 N H R A O N T O V E N T A N U  
 T I O E H S O I N M O H D O D  
 A G W A S T O N I S H I D I E  
 C H M D E A W E A K E N E T L  
 T E O M A N G I V E N G D O Y  
 S R Y R H T E V P A P E R M E  
 C O N T R A C T N E P I R M R  
 A C O M P O S I T I O N H O E  
 H E T A R O M E M M O C R C I

HIGHER • ASTONISH • INSTANT  
 RIPEN • RUDELY • PAPER  
 COMPOSITION • FIRM  
 COMMOTION • CONTRACT • GIVEN  
 CHURLISHLY • ARROW • CONTACTS  
 NOURISH • COMMEMORATE • ADDED  
 SCARF • WEAKEN • OVEN • HIRE  
 SOUGHT • CLOTHING

The factors of 18 are 1 \_\_\_\_\_ 6 \_\_\_\_\_

Circle the relative adverb.  
 After fourth period is when I eat  
 lunch this year.

You ask Jenna for the time.  
 She says it is half-past 8.  
 Write the time on your digital  
 clock:

If sixteen crayons are divided  
 into eight equal rows, how  
 many crayons are in each  
 row?  
 \_\_\_\_\_

Round the number to the  
 place value of the BIG number.

7,8**9**4,457  
 \_\_\_\_\_

Name: \_\_\_\_\_

HOEING • CONTACTS • HIRE • OVEN • SCARF • HIGHER • GIVEN  
ASTONISH • INSTANT

Write each word into the puzzle.

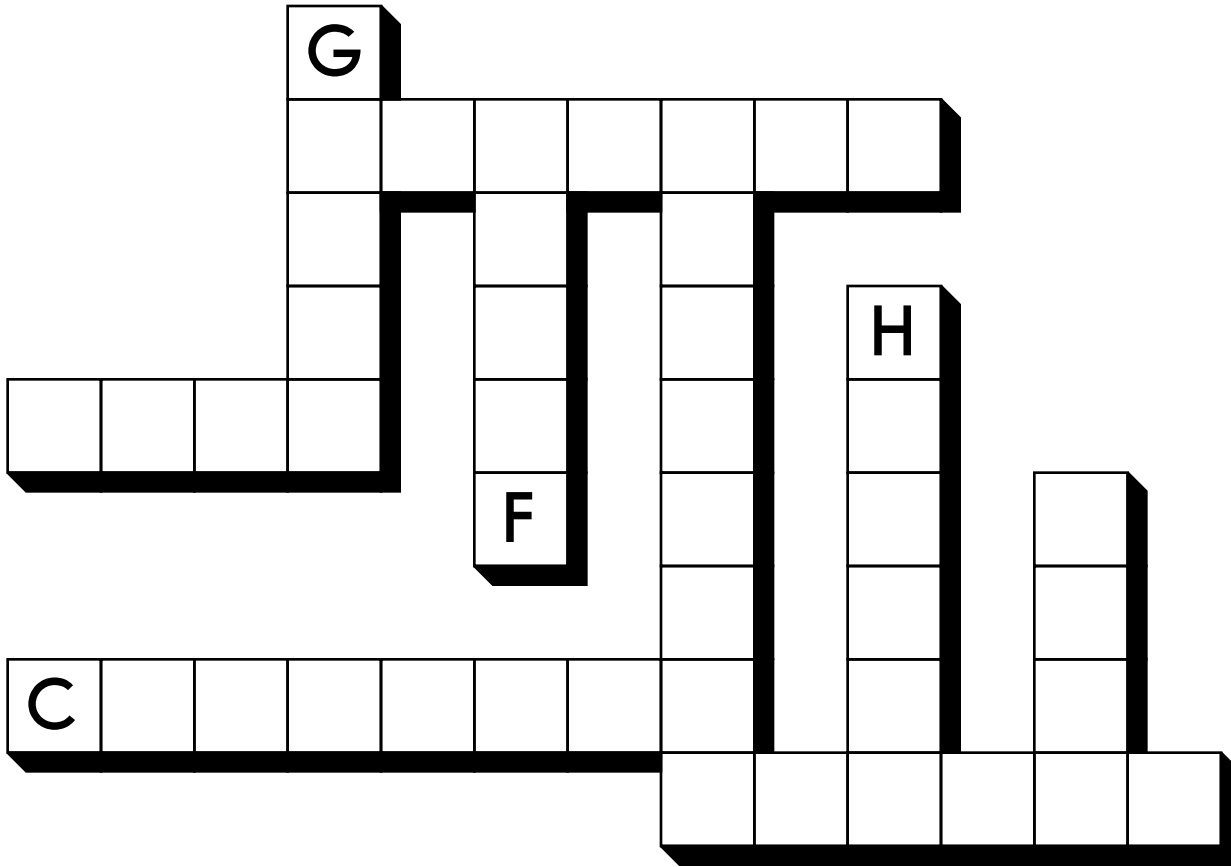

Calculate the product of 3 and 8.  
\_\_\_\_\_

Would you use a ruler or a yardstick to measure the length of the height of your teacher?  
\_\_\_\_\_

$$\begin{array}{r} 92 \\ - 35 \\ \hline \end{array}$$

Name: \_\_\_\_\_

Use each word ONCE. Cross off each word after it is used.

added • perimeter • rudely • hoeing • arrow • astonish • given  
canoeing • hire • churlishly • nourish • instant • repeated  
commotion • weaken • ripen • oven • commemorate • impertinently

These words have  
"oeing" in them.

\_\_ o e i n g \_\_  
\_\_\_\_\_  
\_\_\_\_\_

These words have "ish" in  
them.

\_\_\_\_\_ i s h \_\_\_\_\_  
\_\_\_\_\_  
\_\_\_\_\_

These words have the  
short i sound like in mitten.

\_\_\_\_\_ t e \_\_\_\_\_  
\_\_\_\_\_  
\_\_\_\_\_

These words have "comm" in  
them.

c o m m \_\_\_\_\_  
\_\_\_\_\_  
\_\_\_\_\_

These words  
have the long e  
sound like in  
baby.

r u \_\_\_\_\_ y \_\_\_\_\_  
\_\_\_\_\_

These words have "en" in them.

\_\_\_\_\_ e n \_\_\_\_\_  
\_\_\_\_\_ e n \_\_\_\_\_  
\_\_\_\_\_  
\_\_\_\_\_

Fit the rest of the words into these shapes.

					w
--	--	--	--	--	---

			d	e	
--	--	--	---	---	--

--	--	--	--	--



Name: \_\_\_\_\_

# Oxymorons

Ollie Oxy is hunting for oxymorons, those words or groups of words that have contradictory meanings. Help him by circling the phrases that are oxymorons:

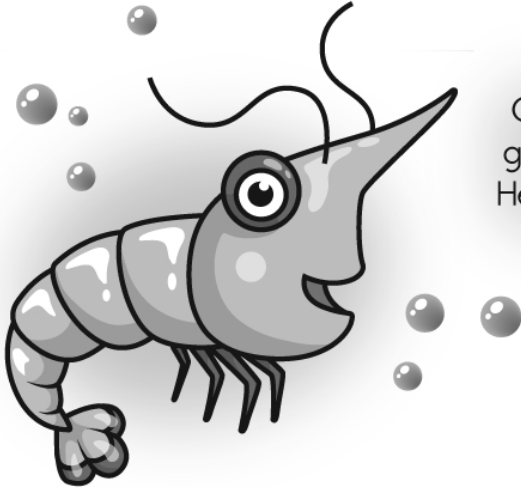

Now draw a picture of your favorite oxymoron here:



- Jumbo shrimp
- Delicious desserts
- Strong winds
- Working vacation
- Spicy hotdogs
- Diet hot fudge sundae
- Act natural
- Hard class
- Pretty ugly
- Cruel kindness
- Organized chaos
- Yellow beachballs
- Green grass
- Pink flamingos

Name: \_\_\_\_\_

weaken • astonish • arrow • scarf • given • commotion

Each row, column, and box must have all the words from the word list. Write in the missing words.

				arrow	astonish
		astonish			weaken
weaken					scarf
	given			scarf	
arrow			astonish	weaken	

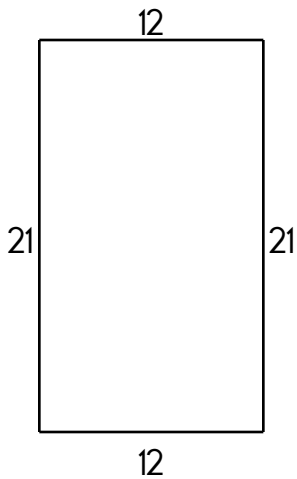

The perimeter is \_\_\_\_\_.

Which number is five hundred twenty-three?

- 523      2,035      5,230  
532

$$8 \overline{)48}$$

Write the length in centimeters.

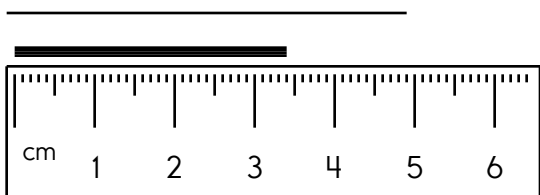

How many days are in May?

\_\_\_\_\_

Share 10 equally among 2.

\_\_\_\_\_

$$7 \overline{)42}$$

Name: \_\_\_\_\_

Use each of the blocks to spell four words.  
Hint: Use the words astonish and firm.

R M    S H    O N    E D    H E

F I    R    ~~S T~~    ~~U N~~    ~~W~~  
~~O~~    ~~G~~    ~~H I~~

1.	A	S	T			I		
2.	W	O	U	N	D			
3.	H	I	G					
4.								

Write the hidden word. Start at one letter and then move either left or right. Continue in same direction.

\_\_\_\_\_

\_\_\_\_\_

\_\_\_\_\_

Circle the words.

arrowfirmripenaddedhoeingrudelyinstantweaken  
 arrowsonewhereaddedweakenrudelyhoeingripen  
 rudelypaperhireripensomewhereweakenhoeingfirm

Name: \_\_\_\_\_

Try to spell some words.

ra • ~~o~~ • te • mo • re • ~~m~~ • wea • dom • ino • co  
ken • mme • oed • ~~t~~ • es • hi • ech • ~~n~~

commotion \_\_\_\_\_  
\_\_\_\_\_

Draw one line to find two words in each puzzle. The bold letters start each word.  
You can move left, right, up, or down. Write the two words that you find.

P U P J I E H T  
I N D R Q A W Z  
B X G E P K N K  
C A D C A **O** V I  
U N L U **P** N E X  
B K E Y D U I K  
L Y B O E A U L  
I S O U I V B H

I I L T V X I I  
I U K Q O P E I  
H B O P M E I D  
O A Q C R E O O  
B Z A H O I N U  
E F E L Q V A O  
L B C **E** D **F** X N  
I D H O E I R M

X Q O U Z E V A  
G L M I A R J H  
I N O I L O **S** C  
Z O J D S V K A  
Q I I X W W O R  
O O R K P O **A** F  
W U O B Y R R X  
P M P P F M P A

\_\_\_\_\_  
\_\_\_\_\_

Write the hidden word. Start at one letter and then move either left or right. Continue in same direction.

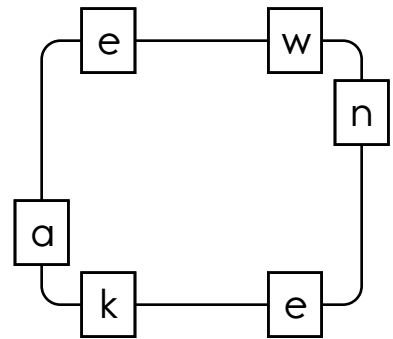
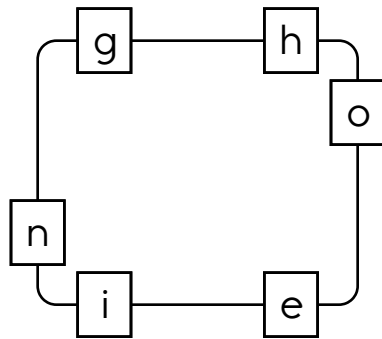
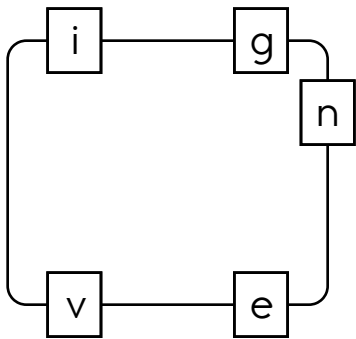

\_\_\_\_\_

Name: \_\_\_\_\_

Which way does each word go? Write the word.

1. ↙ PUZZLE  
← PEOPLE  
→ PIN  
↓ PEASANTS

					<sup>1</sup> P	I	N
/	/	/	/			/	/
/	/	/		/		/	/
/	/		/	/		/	/
/		/	/	/		/	/
	/	/	/			/	/
/	/	/	/	/		/	/
/	/	/	/	/		/	/

1. ↓ AFTERNOONS      2. ↓ EVENTUAL  
↘ APE                    EQUIP  
← AWAKE                EARN  
→ AIM

/					<sup>1</sup> A	I	M
/				<sup>2</sup> E			/
/	/	/		V		/	
/	/		/	E		/	/
/		/	/	N		/	/
	/	/	/	T		/	/
/	/	/	/	U		/	/
/	/	/	/	A		/	/
/	/	/	/	L		/	/

How do you know if a number is divisible by 4? Look at the last two digits of the number.

266,990 Is  divisible by 4?    Yes    No

If Yes, fill in:  ÷ 4 =

Circle one: 266,990 is divisible by four      266,990 is not divisible by four

12,770,290 Is  divisible by 4?    Yes    No

If Yes, fill in:  ÷ 4 =

Circle one: 12,770,290 is divisible by four      12,770,290 is not divisible by four

Circle the coordinating conjunction in this sentence.

I wanted to stay up late reading, but I knew that I would regret that decision in the morning.





Name: \_\_\_\_\_

Draw one line to find two words in each puzzle. The bold letters start each word.  
You can move left, right, up, or down. Write the two words that you find.

**T** **P** E O O P Q U  
A E G P E O A I  
J W A L P I F M  
E **S** S E J R U H  
O N T P Q X Z K  
G S I O P O X H  
O I I T V I O O  
I A K M J N R C  
F U I L O X U E  
Y W P I A Z S E

U Q E U C I S E  
C R S N G N **P** I  
A L T O J C I R  
U R U G X U P A  
Q K O X N S T R  
J O U K I **L** I B  
O A T I G U C Q  
U S W I Y Q Q H  
O H E H A D A O  
K O I G I A O P

N **I** R E S S F R  
E M P F T E I B  
D O A U U L G I  
D N O X B U T M  
U **S** V I G P C O  
A U S E E B Z J  
O J Q L C J T O  
O T O A R P W P  
E E A R O E I B  
D C U W I I H Q

\_\_\_\_\_  
\_\_\_\_\_

\_\_\_\_\_  
\_\_\_\_\_

\_\_\_\_\_  
\_\_\_\_\_

Use each of the letters to fill in the grid.  
Write two words.

<b>H</b>					

**I** **N** **U**

**R**

**K**

**E**

**E** **T**

Do parallel lines intersect?

\_\_\_\_\_

Erin made 5.5 pounds of pretzels. She put them in bags. Each bag weighed 8 ounces. How many bags of pretzels could she make?

Insert a comma in the appropriate place in this sentence.

My mother fried me an egg for breakfast but I was really in the mood for scrambled eggs this morning.

If  $\square = 9$ , then  $16 - \square =$  \_\_\_\_\_

How many inches are in one foot?

\_\_\_\_\_

bihr

bare

biro

bero



Name: \_\_\_\_\_

### Sudoku Sums of 10

Each row, column, and box must have the numbers 1 through 6.  
Hint: Look for sudoku sums. The sum of the two boxes inside of the dashed lines is 10.

Here is an example of a sudoku sum of 10:

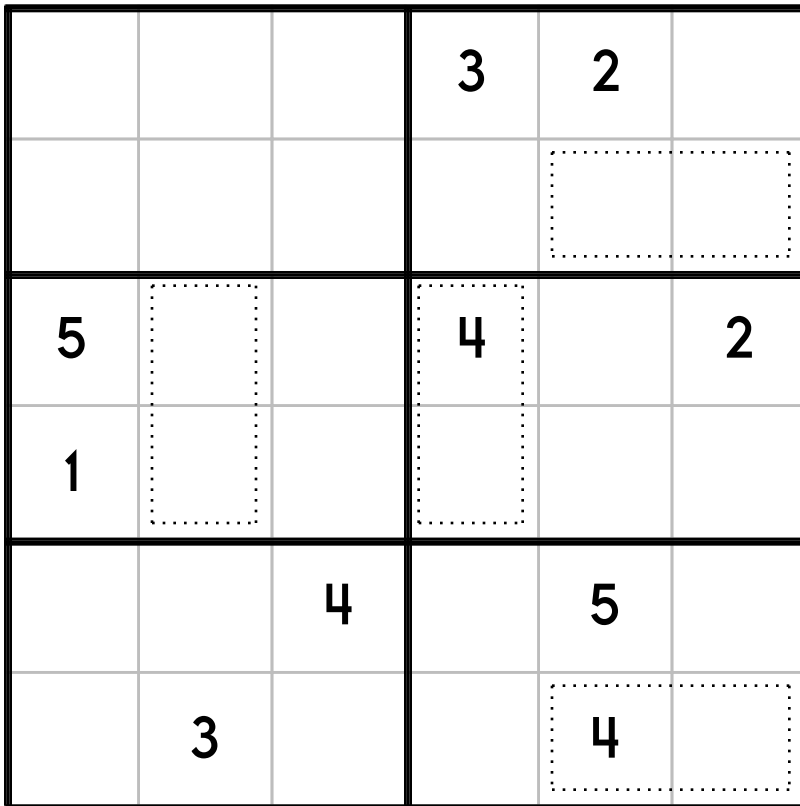

Fill in the blanks with these numbers:

**1, 3, 5**

$$1 \quad \square$$

$$3 \quad 3$$

$$+ \begin{array}{|c|c|} \hline \square & \square \\ \hline \end{array}$$

$$\hline 7 \quad 9$$

Fill in the blanks with these numbers:

**5, 3, 7**

$$\square \quad 2$$

$$\square \quad 1$$

$$+ \quad 1 \quad 4$$

$$\hline 9 \quad \square$$

Which part of the incomplete sentence is missing?

Sam quickly.

- (A) subject                       (B) direct object  
 (C) predicate

Write two odd numbers that when added together equal the even number 18.

\_\_\_\_\_

Name: \_\_\_\_\_

Did you know that you don't always have to use the word **destroyed** in your writing? Try to use different words for an overused word like **destroyed**. It will make your work more fun for others to read.

Circle words to the RIGHT or DOWN. Every letter is used exactly ONCE.

D	E	V			
E	R	D	A	R	A
M	A	E	N	W	R
O	D	C	D	E	C
L	I	I	A	R	A
I	C	M	L	U	V
S	A	A	I	I	A
H	T	T	Z	N	G
E	E	E	E	E	E
D	D	D	D	D	D

Write the words found.

RAVAGED _____	WRECKED _____	_____
_____	_____	_____
_____	_____	_____

Write something using the word **destroyed** at least two times.

---



---



---

Now rewrite your boring writing without using the word **destroyed**.

I can't wait to read it!

---



---



---



---

How many words do you think it takes to improve your writing?

Fifty. That's 50! There are about 50 overused words we often use in writing and conversations.

When you find yourself repeating, try something different. It doesn't take much work to sound amazing!

Name: \_\_\_\_\_

One letter is missing from each word.

B A R O M E T E R

M U S C

L O Y A

W H N E V E R

B L E

C O T O N

T H U G H T

These are a little harder with two letters missing.

S T

R E S T I N

I E

W A D D

E X C A T E

K N

S E R T

A F L I T

Write your own words!

\_\_\_\_\_

\_\_\_\_\_

\_\_\_\_\_

\_\_\_\_\_

\_\_\_\_\_

\_\_\_\_\_